

# ***HWH® Hand/Electric Pump with Remote Operating Panel and Manual Back-up***

***Available for Fifth Wheel, Horse & Specialty Trailers***



## **Includes the following features...**

- 12 volt DC electric pump provides hydraulic pressure for jacks and rooms.
- The solenoids allow the operator to extend or retract jacks and rooms with electrically operated switches.
- Switches can be remote mounted for easy access.
- The integrated manual hand pump is the perfect back-up in the event of a dead battery.

Manual hand pump extends and retracts HWH® jacks or rooms with minimal effort. No electrical power is required.

The power unit is equipped with a manual two-stage hand pump which automatically shifts from high-volume with low-pressure to low-volume with high-pressure. This provides a rapid extend of the landing gear, but also gives you the power to lift a sizeable load.

The base of the hand pump swivels 180 degrees to allow more flexibility in mounting the controls.



(On I-80, Exit 267 South) | 2096 Moscow Road | Moscow, Iowa 52760  
Phone: (800)321-3494 or (563)724-3396 | Fax: (563)724-3408 | Web: [www.HWH.com](http://www.HWH.com)  
***Made in the USA***

**STRONG, RELIABLE, HYDRAULIC POWER**

# Specifications & Features

## The HWH<sup>®</sup>: Power Unit with Solenoids and Manual Back-up

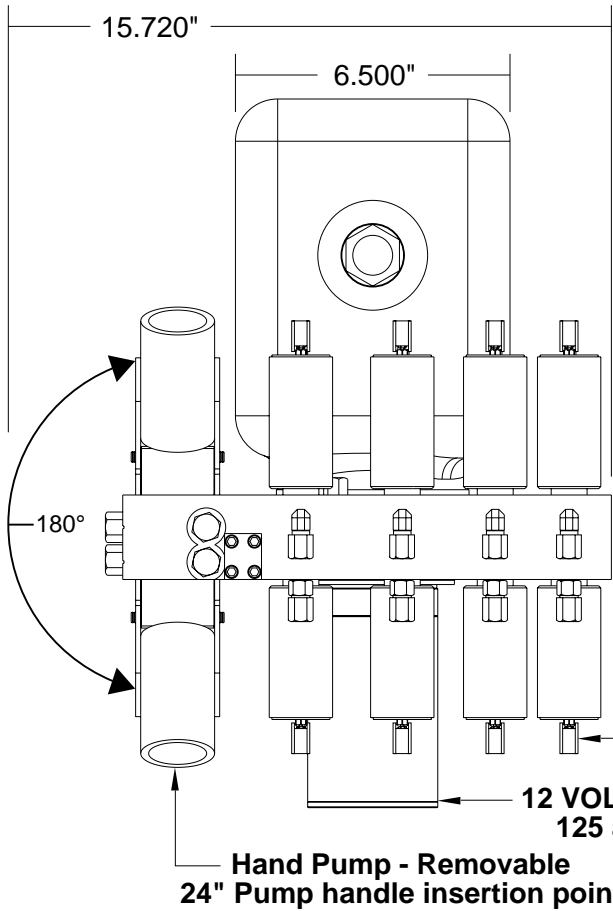

Up to four pairs of solenoid valves will operate up to four one way jacks, four two way jacks or four room extensions or a combination there of.

Each solenoid valve is equipped with a manual release to be used during hand pump operations.

### Specifications...

#### WEIGHT (lbs.)

Each Assembly	32
---------------	----

#### TANK LENGTH - OIL DELIVERY (Cubic inches)

10.0" Tank - 165 cu in

13.5" Tank - 250 cu in

19.0" Tank - 360 cu in

