

## Specifications

### The HWH® SpaceMaker® : Dual Cylinder "Level Out" Room Extension (With HWH Synchronizing Cylinder)

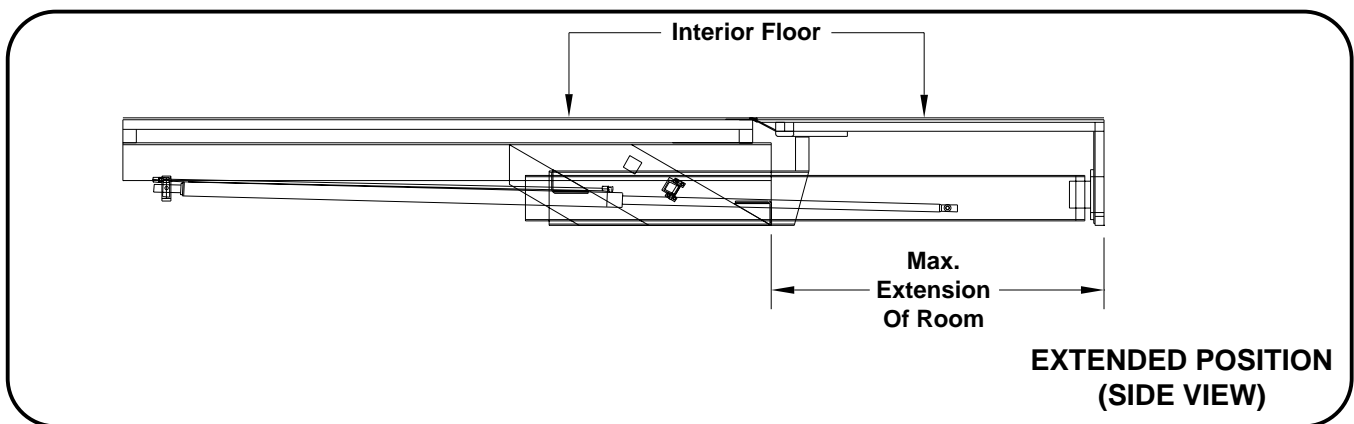
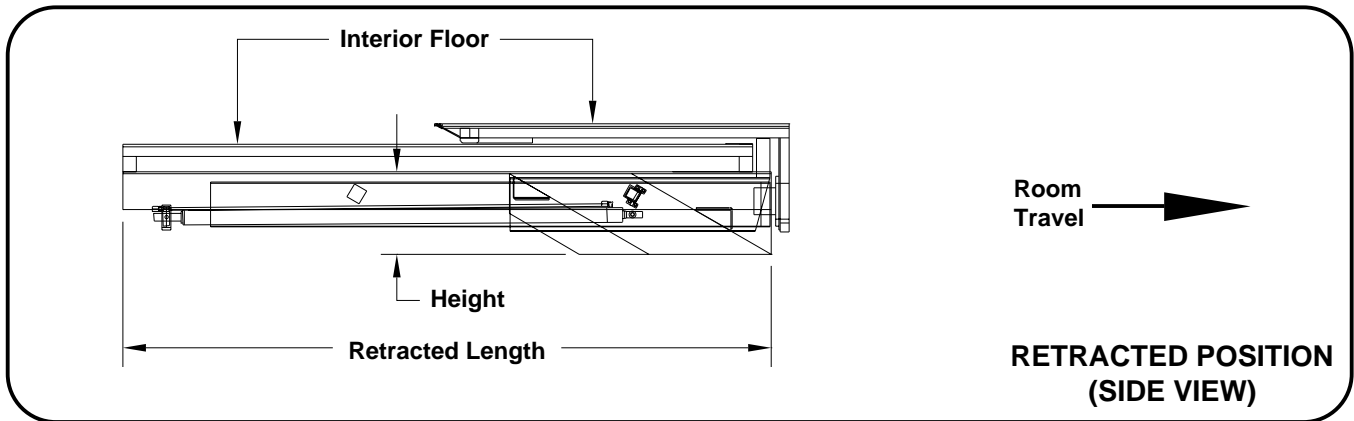

**NOTE:** SPECIFICATIONS VARY FOR DIFFERENT MODELS.

<b>SPECIFICATIONS FOR SHOWN MODEL</b>	
<b>WEIGHTS (lbs.)</b>	
Mechanism Assembly (2 Rails)	208.00
Synchronizing Cylinder	15.50
Pump *	14.20
<b>Gross Weight *</b>	<b>237.70</b>
<b>DIMENSIONS (in.)</b>	
Width (Each Rail)	8.00
Height (Each Rail)	9.40
Length (Retracted)	72.00
<b>Max. Extension of Room</b>	<b>35.00</b>
<b>LOAD per ARM ** (lbs.)</b>	<b>500.00</b>
<b>FORCE of CYLINDER (lbs.)</b>	
Max. Extending	2,100.00
Max. Retracting	2,100.00
<b>PRIMARY APPLICATION</b>	
Any Suitable Room	Below Floor

\* If coach is equipped with an HWH Leveling System, pump is included.

\*\* Load includes all occupants, cargo, room and permanent fixtures resting on room.