

PRESSURE SWITCH INSTALLATION FOR REAR OF DODGE SPRINTER CHASSIS

NOTE: INSTALL PRESSURE SWITCH ON JACK CYLINDER BEFORE MOUNTING CYLINDER ON JACK WRAPPER.

FOR AP37942 JACK KIT (#4000 JACKS)

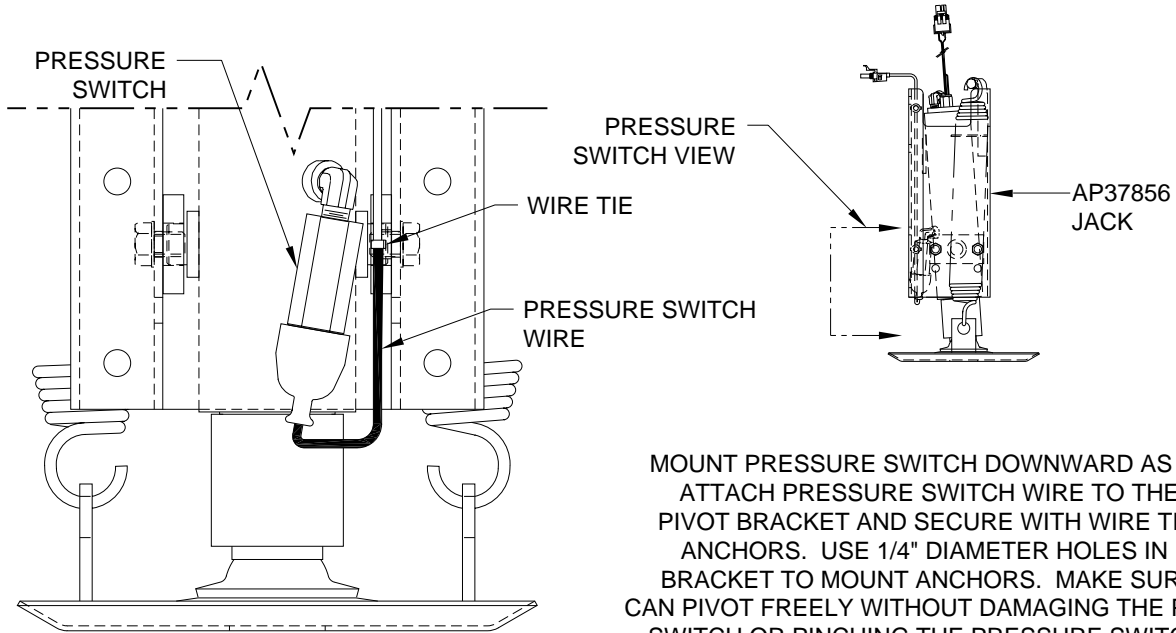

MOUNT PRESSURE SWITCH DOWNWARD AS SHOWN. ATTACH PRESSURE SWITCH WIRE TO THE JACK PIVOT BRACKET AND SECURE WITH WIRE TIES AND ANCHORS. USE 1/4" DIAMETER HOLES IN PIVOT BRACKET TO MOUNT ANCHORS. MAKE SURE JACK CAN PIVOT FREELY WITHOUT DAMAGING THE PRESSURE SWITCH OR PINCHING THE PRESSURE SWITCH WIRE.

FOR AP37524 JACK KIT (#6000 JACKS)

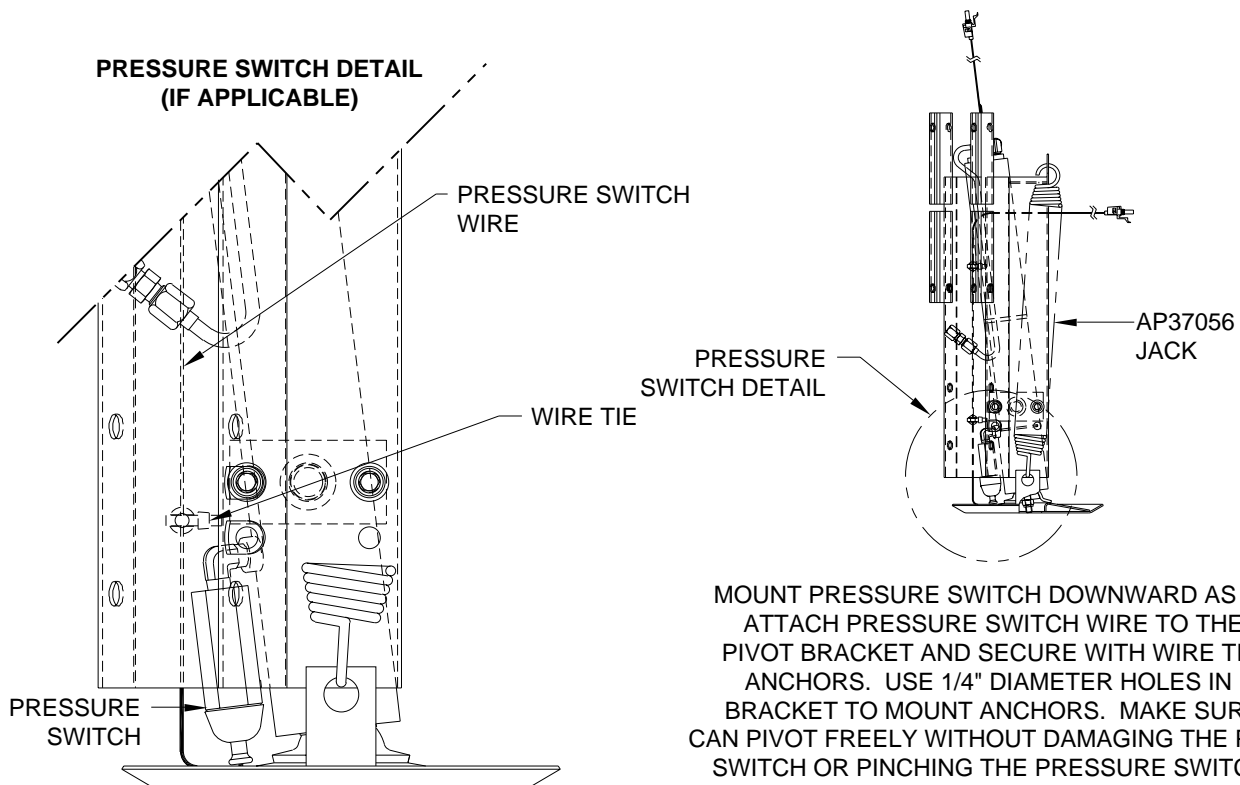

MOUNT PRESSURE SWITCH DOWNWARD AS SHOWN. ATTACH PRESSURE SWITCH WIRE TO THE JACK PIVOT BRACKET AND SECURE WITH WIRE TIES AND ANCHORS. USE 1/4" DIAMETER HOLES IN PIVOT BRACKET TO MOUNT ANCHORS. MAKE SURE JACK CAN PIVOT FREELY WITHOUT DAMAGING THE PRESSURE SWITCH OR PINCHING THE PRESSURE SWITCH WIRE.

CAUTION: Follow CAUTIONS in Operator's and Installation Manuals concerning working under vehicles.

**MI15.2008
21MAY08**