

# QUICK REFERENCE GUIDE

## ACTIVE AIR LCD SYSTEM CONTROL PANEL

This is an interactive guide to show and explain the functions and display screens of the LCD system control panel for Active Air Systems.

Click on any highlighted area to advance to another screen or to a page with detailed explanations of the control buttons, indicator lights or status information on a particular screen.

It is important to remember that not all systems have the same screens or functions. For example, your screen may not have hydraulic leveling information or functions.

In the status page section, room status is not included. Room status is accessed from the individual room operation page or from the main room page. Also in the status page section, status pages for air suspension, air leveling, and hydraulic leveling are included with every system. If your system is not equipped with hydraulic leveling or a tag axle, ignore pages or information concerning that equipment.

Clicking on the **“HOME”** button on any page will return you to the initial HOME PAGE screen.

HOME PAGE 3 is not displayed in this quick reference guide. HOME PAGE 3 contains access to and information about system settings and parameters. You must contact HWH to access information on HOME PAGE 3.

The system control screen will display messages and warnings that are not shown in this quick reference guide.

**CLICK HERE TO CONTINUE TO HOME PAGE 1 SCREEN**

# CONTROL IDENTIFICATION

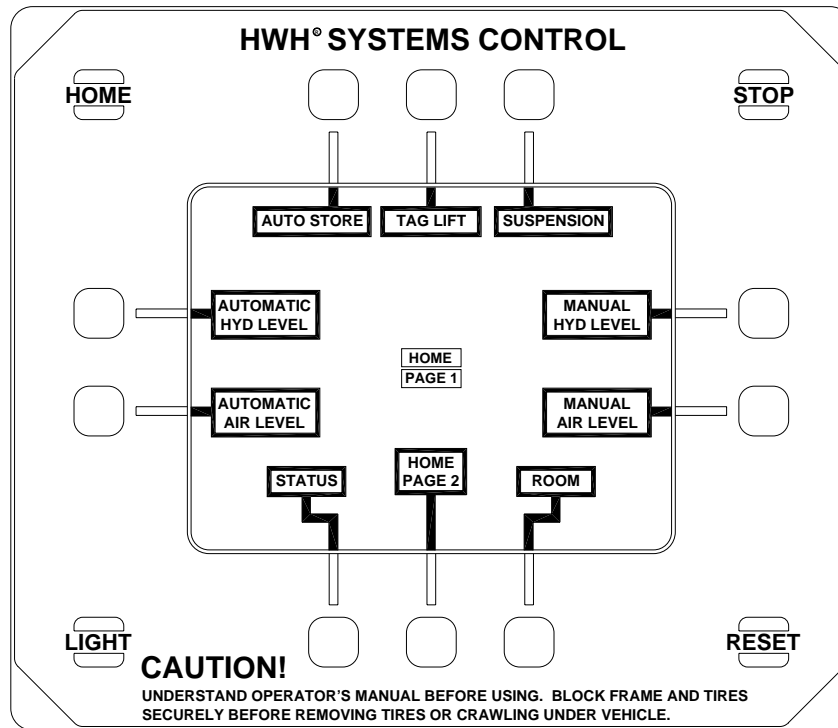

## HOME PAGE

**NOTE:** See individual function pages in the OPERATING PROCEDURES section of this manual for detailed information about specific screen buttons.

## PANEL BUTTONS

**"HOME" BUTTON:** Pushing the "HOME" button at any time will return the control panel to HOME PAGE 1 EXCEPT when the system is actively leveling the vehicle in an automatic mode.

**"LIGHT" BUTTON:** Pushing the "LIGHT" button will turn the back light off. The panel will appear dark but the system will remain on. Push the "LIGHT" button to turn the back light on.

**"STOP" BUTTON:** Pushing the "STOP" button will turn the system off halting any active function including ACTIVE AIR SUSPENSION. If the ignition is on, the Master Warning Light will come on. **IT IS NOT RECOMMENDED TO PUSH THE "STOP" BUTTON WHEN TRAVELING.**

**"RESET" BUTTON:** This button will reset the SYSTEM CONTROL PANEL if the panel ceases to function due to a malfunction. The "RESET" button will also reactivate the CONTROL PANEL if the "STOP" button is pushed at ANY time. The ignition key must be on for the "RESET" button to work.

## SCREEN BUTTONS AND LIGHTS

**"AUTOMATIC HYD LEVEL" BUTTON:** This button will start the automatic hydraulic leveling procedure and bring up the AUTOMATIC HYD LEVEL screen.

**"AUTOMATIC AIR LEVEL" BUTTON:** This button will start the automatic air leveling procedure and bring up the AUTOMATIC AIR LEVEL screen.

**"MANUAL HYD LEVEL" BUTTON:** This button will put the system in the manual hydraulic leveling mode and bring up the HYD LEVEL page for manual hydraulic leveling control.

**"MANUAL AIR LEVEL" BUTTON:** This button will put the system in the manual air leveling mode and bring up the AIR LEVEL page for manual air leveling control.

**"AUTO STORE" BUTTON:** This button will retract the jacks when manual or automatic hydraulic leveling has been used. It also puts the system in the Travel Mode. If Manual or Automatic Air Leveling was used, this button will put the system in the Travel Mode. No matter what type of leveling was done, when the "AUTO STORE" button is pushed the first thing that happens is air is pumped into all the suspension air bags for 10 seconds before the jacks are retracted and/or the system returns to the Travel Mode.

HOME PAGE 1 button and  
light description continued on  
next page. [Click here.](#)

# CONTROL IDENTIFICATION

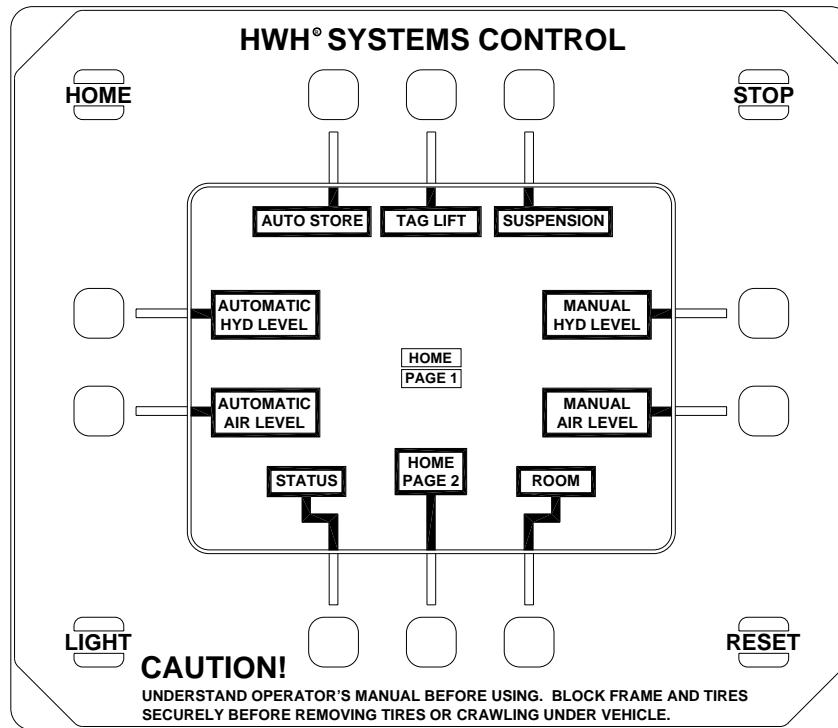

## HOME PAGE CONTINUED

### SCREEN BUTTONS AND LIGHTS CONTINUED

**"AUTO STORE" LIGHT:** This light will flash as "STORING" when the "AUTO STORE" button is pushed. If Hydraulic Leveling was used, this light will flash while the jacks are retracting plus 1 minute after all the jack down indicators are off. If Air Leveling was used, this light will flash for approximately 80 seconds.

**"SUSPENSION" BUTTON:** This button will bring up the Suspension Control page.

**"SUSPENSION" LIGHT:** This light will flash as "SUSPENSION INITIALIZING" until the suspension reaches ride height if the "AUTO STORE" button is pushed and the ignition key is on. If no Leveling System has been used, the "SUSPENSION INITIALIZING" light will flash until the suspension reaches ride height when the ignition key is turned on. Any time the "SUSPENSION INITIALIZING" light is flashing, the Master Warning Light should be on.

**"TAG LIFT" BUTTON:** This button will lift the tag axle. See the "TAG LIFT" section in "OPERATING PROCEDURES".

**"TAG LIFT" LIGHT:** When the letters are black and the background is white, the tag lift is off. The tag axle should be in the Travel Position. When the letters are white and the background is black, the tag lift feature is on. The tag axle should be in the Lift Position.

**"STATUS" BUTTON:** This button will bring up the first "STATUS" page. There will be multiple "STATUS" pages. The "PAGE DOWN" button on a "STATUS" page will advance the screen to the next "STATUS" page. The "STATUS" pages show the status or position of different systems and equipment. This includes items such as ACTIVE AIR SUSPENSION, air or hydraulic leveling, rooms and warning devices. Holding the "STATUS" button on the "HOME" page or the "PAGE DOWN" button on the "STATUS" pages will scroll through the different "STATUS" pages.

**"HOME PAGE 2" BUTTON:** This button will bring up HOME PAGE 2 showing different functions available. HOME PAGE 3 will be accessed from HOME PAGE 2.

**NOTE: Some of the PANEL and SCREEN buttons will react as soon as they are pressed but some buttons will not react until they are released.**

**"ROOM" BUTTON:** This button will bring up the room control screen. Only room 1 and 4 are controlled with the LCD panel. Room 2 has a separate key switch panel.

# CONTROL IDENTIFICATION

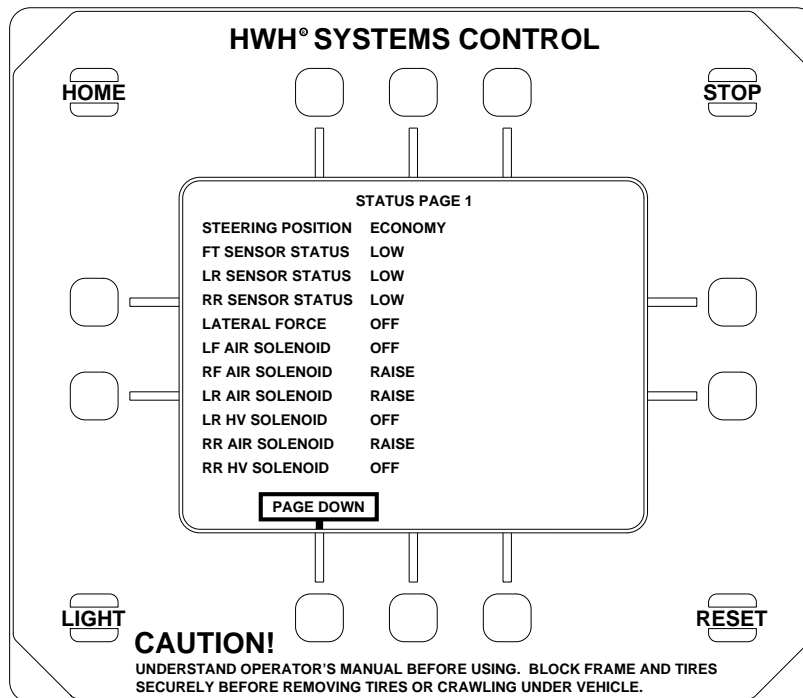

## STATUS PAGE 1

### SCREEN BUTTONS

**"PAGE DOWN" BUTTON:** Use this button to switch from status screen to status screen.

### SCREEN TEXT

#### "STEERING POSITION"

ECONOMY - Normal operating mode. Designed to conserve air (Straight roads)

FLY - Active response to driving conditions (Windy conditions or curvy roads)

#### "FT SENSOR STATUS"

#### "LR SENSOR STATUS"

#### "RR SENSOR STATUS"

HIGH - Indicates selected sensor is ABOVE ideal set point.

LOW - Indicates selected sensor is BELOW ideal set point.

CHANGING - Sensor is "dithering" ABOVE and BELOW ideal set point.

INACTIVE - Indicates sensor is not changing state within allowed time.

#### "LATERAL FORCE"

OFF - Vehicle is not experiencing high side loads.

ON - Vehicle is experiencing high side loads. Will keep system in "FLY" mode.

#### "LF AIR SOLENOID"

#### "RF AIR SOLENOID"

#### "LR AIR SOLENOID"

#### "LR HV SOLENOID"

#### "RR AIR SOLENOID"

#### "RR HV SOLENOID"

RAISE - Air supply is allowed into air bag. (Filling)

LOWER - Air supply is allowed out of air bag (Releasing)

OFF - No air is allowed into or out of air bag.

[RETURN to status page 1 screen](#)

# CONTROL IDENTIFICATION

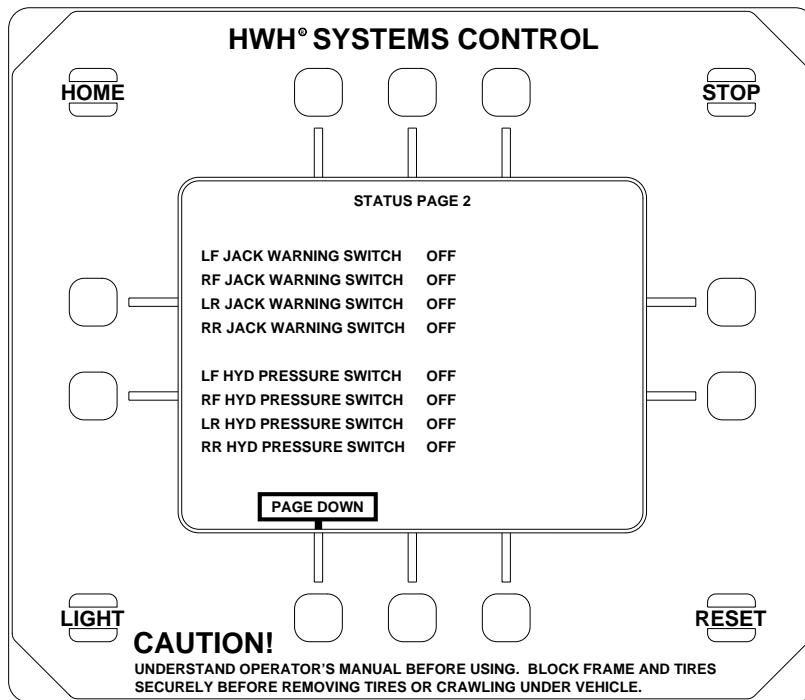

## STATUS PAGE 2

**NOTE:** This "STATUS PAGE" is specific to HWH hydraulic leveling systems ONLY.

### SCREEN BUTTONS

**"PAGE DOWN" BUTTON:** Use this button to switch from status screen to status screen.

### SCREEN TEXT

**"LF JACK WARNING SWITCH"**

**"RF JACK WARNING SWITCH"**

**"LR JACK WARNING SWITCH"**

**"RR JACK WARNING SWITCH"**

OFF - Jack is "FULLY" retracted

ON - Jack is extended

**"LF HYD PRESSURE SWITCH"**

**"RF HYD PRESSURE SWITCH"**

**"LR HYD PRESSURE SWITCH"**

**"RR HYD PRESSURE SWITCH"**

OFF - Jack has no load on it, It is not supporting weight.

ON - Jack has load on it, it is supporting weight.

[RETURN to status page 2 screen](#)

# CONTROL IDENTIFICATION

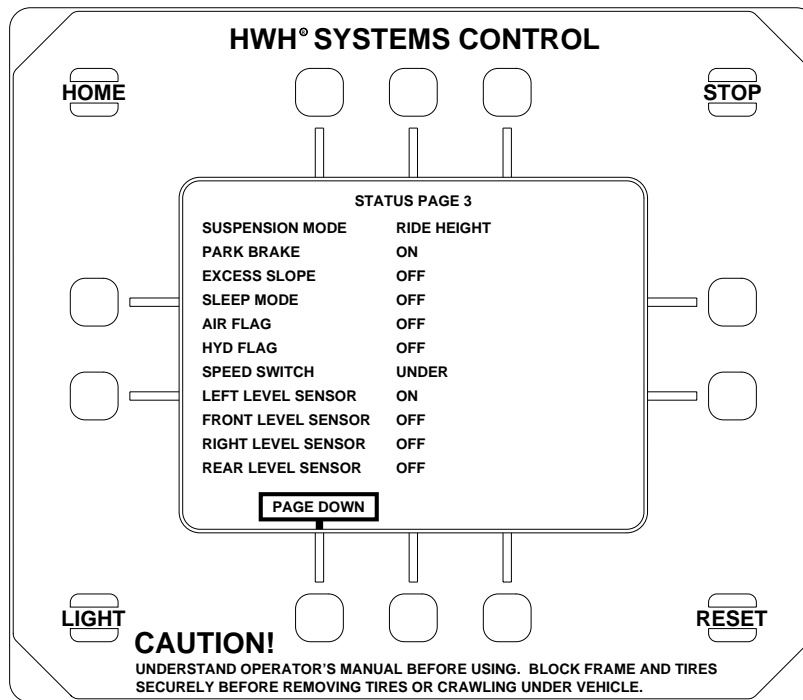

## STATUS PAGE 3

### SCREEN BUTTONS

**"PAGE DOWN" BUTTON:** Use this button to switch from status screen to status screen.

### SCREEN TEXT

#### "SUSPENSION MODE"

RIDE HEIGHT - System is in Active Air.

OFF - System is not in Active Air.

#### "PARK BRAKE"

#### "EXCESS SLOPE"

"SLEEP MODE" - Is in sleep mode air leveling.

"AIR FLAG" - Has been leveled using air.

"HYD FLAG" - Has been leveled using hydraulics.

OFF -

ON -

#### "SPEED SWITCH"

UNDER - Vehicle is under speed. System will not enter "FLY" mode.

OVER - Vehicle is over speed. System will not enter "FLY" mode.

#### "LEFT LEVEL SENSOR"

#### "FRONT LEVEL SENSOR"

#### "RIGHT LEVEL SENSOR"

#### "REAR LEVEL SENSOR"

OFF -

ON -

[RETURN to status page 3 screen](#)

# CONTROL IDENTIFICATION

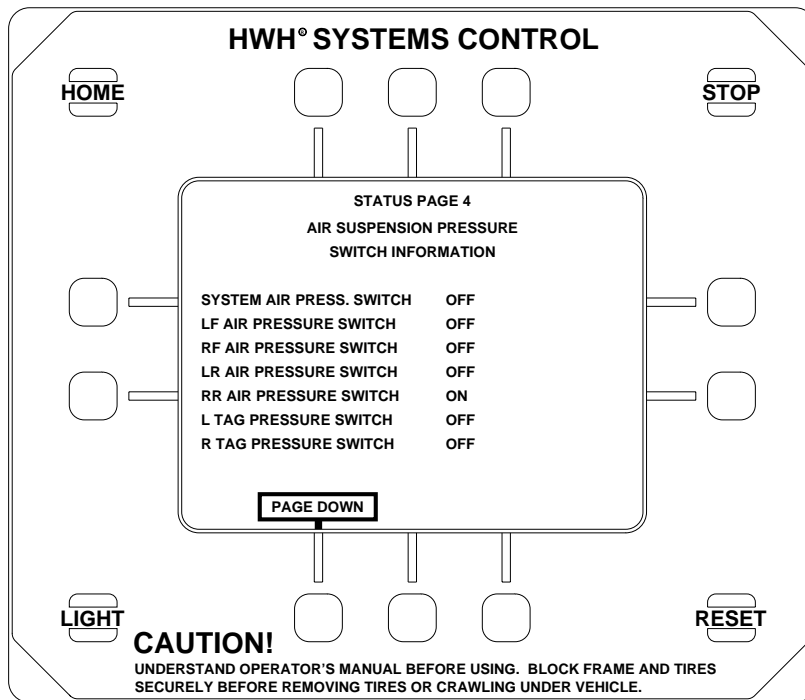

## STATUS PAGE 4

### SCREEN BUTTONS

**"PAGE DOWN" BUTTON:** Use this button to switch from status screen to status screen.

### SCREEN TEXT

**"SYSTEM AIR PRESS. SWITCH"**

**"LF AIR PRESSURE SWITCH"**

**"RF AIR PRESSURE SWITCH"**

**"LR AIR PRESSURE SWITCH"**

**"RR AIR PRESSURE SWITCH"**

**"L TAG PRESSURE SWITCH"**

**"R TAG PRESSURE SWITCH"**

OFF - Air bag does not have sufficient air pressure.

ON - Air bag does not have sufficient air pressure.

[RETURN to status page 4 screen](#)

# OPERATING PROCEDURES

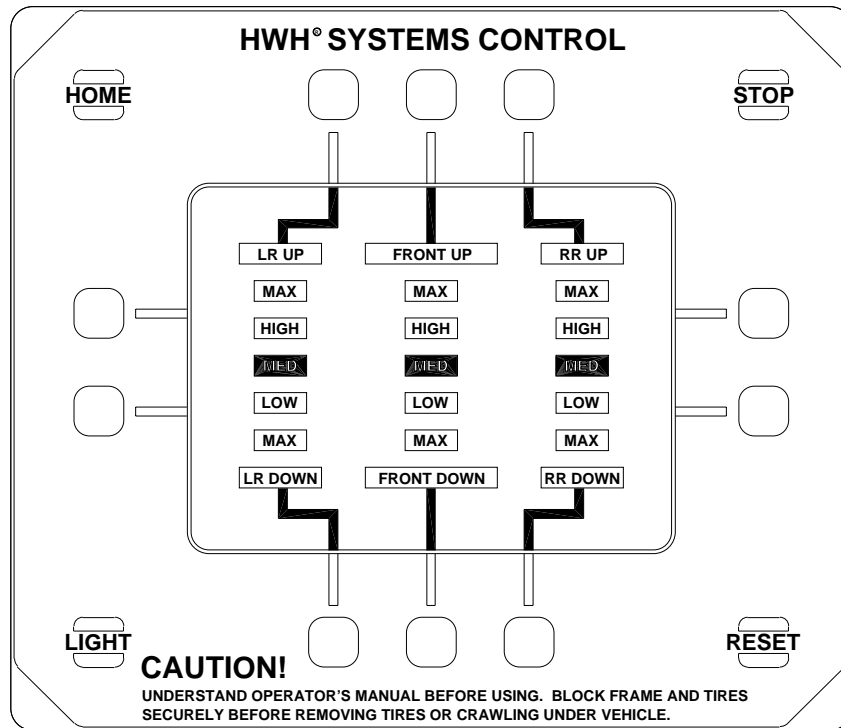

## SUSPENSION CONTROL

This screen is used to control the ride height of the vehicle while traveling or moving slowly.

Push UP or DOWN buttons to move the indicator light one position.

**NOTE: Pushing and holding a button will move an indicator one position only.**

### BUTTONS

**LR UP:** This will add air to the LEFT REAR air bags to raise the vehicle.

**FRONT UP:** This will add air to the FRONT air bags to raise the vehicle.

**RR UP:** This will add air to the RIGHT REAR air bags to raise the vehicle.

**LR DOWN:** This will exhaust air from the LEFT REAR air bags to lower the vehicle.

**FRONT DOWN:** This will exhaust air from the FRONT air bags to lower the vehicle.

**RR DOWN:** This will exhaust air from the RIGHT REAR air bags to lower the vehicle.

[RETURN to suspension control screen](#)

## INDICATORS

**MED:** When the indicator is in this position the suspension should be at the normal ride height for traveling.

**HIGH:** When the indicator is in this position the suspension should be approximately one (1) inch HIGHER than normal ride height.

**LOW:** When the indicator is in this position the suspension should be approximately one (1) inch LOWER than normal ride height.

**MAX:** When this indicator is in this position, the suspension will be at it's MAXIMUM height if an UP button is used OR the suspension will be at it's LOWEST point if a DOWN button is used.

**NOTE: The system monitors the transmission speed switch. The system will not allow the suspension to move to the MAX position, UP or DOWN when the vehicle is moving faster than the setting of the speed switch. This is usually between 5 MPH to 15 MPH.**

If the suspension is set to the MAX position, when the setting of the speed switch is exceeded, the system will default to the MED position. This would be normal ride height for the vehicle.

**IMPORTANT: Any time the RESET button is pushed while traveling, the system will default to the MED position, normal ride height.**

# OPERATING PROCEDURES

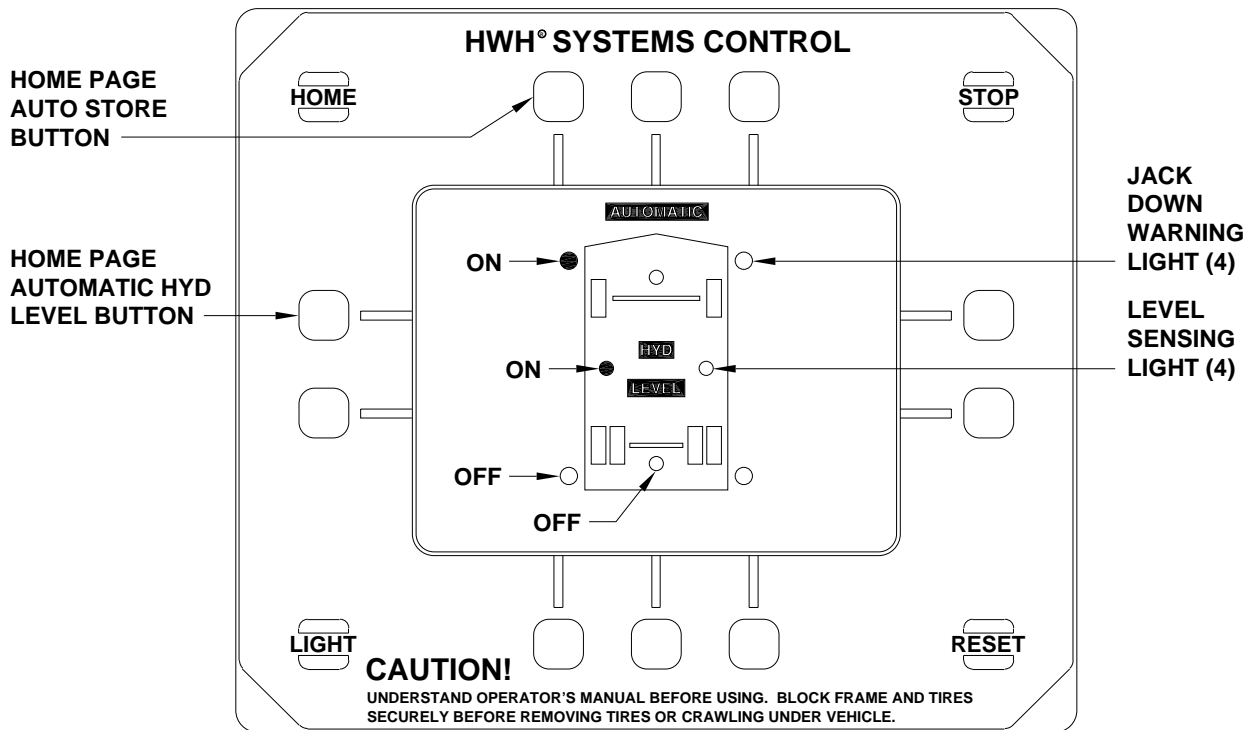

## AUTOMATIC HYDRAULIC LEVELING

**CAUTION: KEEP PEOPLE AND OBJECTS CLEAR OF THE VEHICLE WHILE OPERATING THE HYDRAULIC LEVELING SYSTEM.**

The ignition key must be on and the park brake must be set to use automatic hydraulic leveling. If the ignition and/or the park brake are not on, a message will appear on the screen when the "AUTOMATIC HYD LEVEL" button is pushed. Push the "HOME" button and correct the problem before pushing the "AUTOMATIC HYD LEVEL" button again.

**NOTE: Automatic leveling and automatic store can only be started when the "HOME" page is being displayed.**

The system will level the vehicle according to level sensing lights. A lit level sensing light indicates that side, end or corner of the vehicle is low. When all level sensing lights are out the vehicle is level.

The Jack Down Warning Lights will come on as there respective jack extends approximately 1 inch.

1. Turn the ignition key on and set the park brake.
2. At this time, the operator may want to check the jacks. Place a pad under each jack at this time, if necessary.

3. Push the AUTOMATIC HYD LEVEL button on the HOME page. The AUTOMATIC HYD LEVEL page will appear.

4. The air will dump from the suspension for 30 seconds when the AUTOMATIC HYD LEVEL button is pushed. Leveling will start after the 30 second dump time.

5. The system will extend the jacks as necessary according to the level sensing lights starting with any lit side lights.

6. When all the level lights are out, the system will extend any remaining jacks to the ground to stabilize the vehicle.

7. When the leveling sequence is completed a message confirming this will appear on the screen.

8. Push the "HOME" button and turn the ignition off or continue with other functions.

**EXCESS SLOPE:** Excess slope is two jacks extending fully with out turning that level sensing light out. In the event the jacks are unable to level the vehicle, the control screen will display a message stating the attempt to level was unsuccessful. One or more jacks may not be extended. Push the "HOME" button to return to the HOME page. Use "AUTO STORE" to retract the jacks. Move the vehicle to a more level position or level the vehicle as close as possible according to the MANUAL HYD LEVEL section.

# OPERATING PROCEDURES

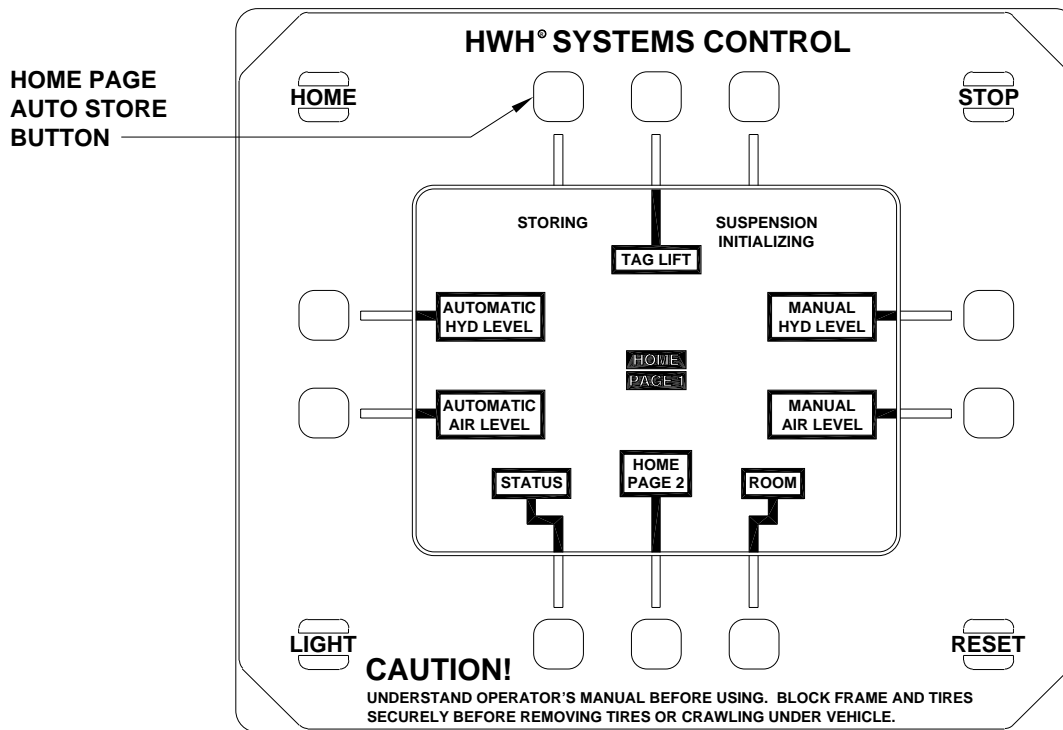

## JACK RETRACTION

Jack retraction is achieved from the "HOME" page. The "AUTO STORE" button can be used with the ignition and park brake on or off as long as the control panel screen is on at the "HOME" page.

If the vehicle was leveled with the hydraulic leveling system, the vehicle will not return to ride height unless the "AUTO STORE" button is used to retract the jacks. Also the ignition key must be on for the vehicle to return to ride height.

**CAUTION: THE OPERATOR MUST BE SURE THAT THERE ARE NO OBJECTS UNDER THE VEHICLE AND THAT ALL PEOPLE ARE CLEAR OF THE VEHICLE.**

1. Turn a room panel key or ignition key on to turn the CONTROL PANEL on. If preparing to travel, start the engine.

2. Push the "AUTO STORE" button. The "AUTO STORE" light will flash as "STORE". The system will put air into the air bags for 10 seconds before the jacks start to retract. Approximately 20 seconds after pushing "AUTO STORE", the "SUSPENSION" light (if the ignition key is on) will start to flash as "SUSPENSION INITIALIZING".

3. As each jack retracts fully, its jack down indicator will go out. (The panel does not show this). One minute after all the jacks are fully retracted, the "STORE" light will stop flashing and revert to a solid AUTO STORE light.

4. When the suspension attains the proper ride height, the "SUSPENSION INITIALIZING" light will stop flashing and will be displayed as "SUSPENSION".

5. Check that the jacks are retracted and the vehicle is at the proper ride height for traveling before proceeding.

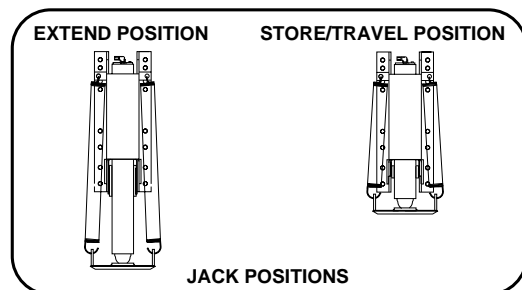

**CAUTION: DO NOT MOVE THE VEHICLE WHILE THE LEVELING JACKS ARE STILL IN CONTACT WITH THE GROUND OR IN THE EXTEND POSITION. THIS VEHICLE IS EQUIPPED WITH STRAIGHT-ACTING JACKS. MOVING THE VEHICLE WITH THE LEVELING JACKS EXTENDED CAN CAUSE SEVERE DAMAGE TO THE JACKS AND OR THE VEHICLE AND CREATE A DRIVING HAZARD. DO NOT RELY SOLELY UPON WARNING LIGHTS. IT IS THE OPERATOR'S RESPONSIBILITY TO CHECK THAT ALL JACKS ARE FULLY RETRACTED INTO THE STORE/TRAVEL POSITION AND THE VEHICLE IS AT THE PROPER RIDE HEIGHT.**

# OPERATING PROCEDURES

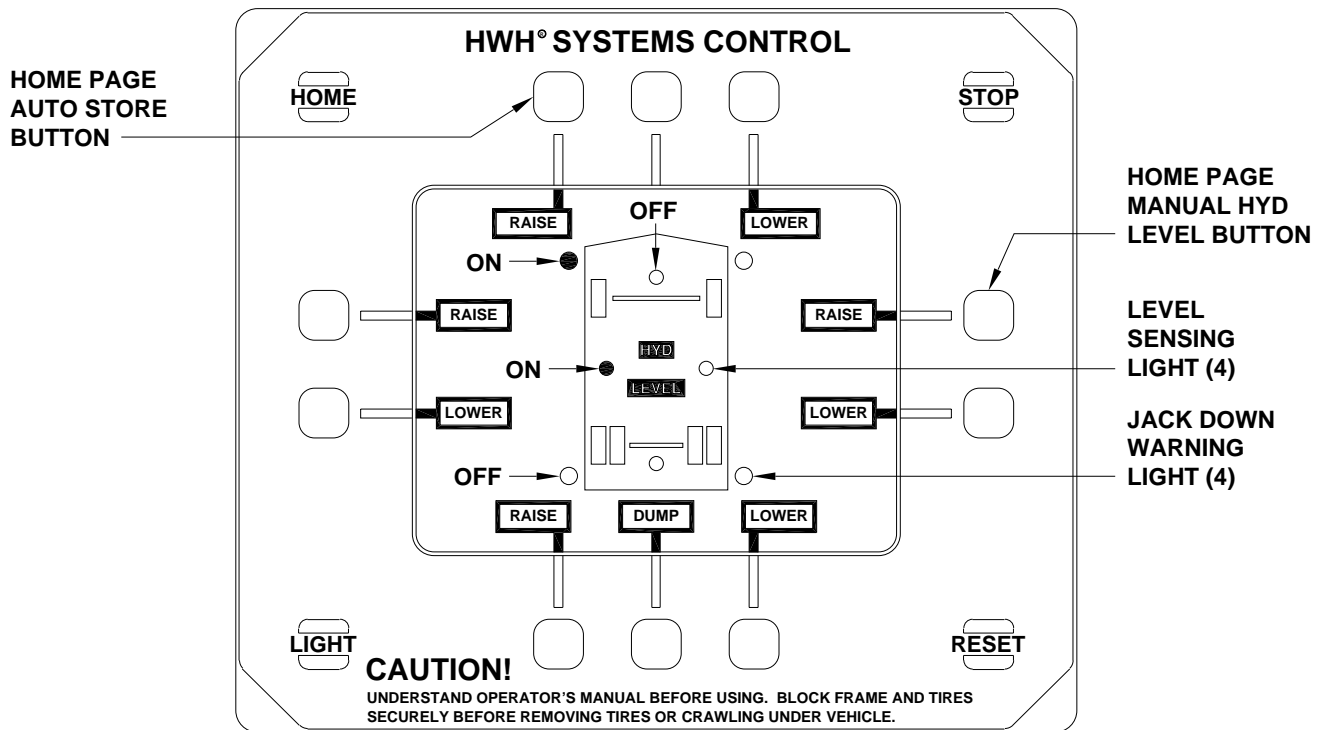

## MANUAL HYDRAULIC LEVELING

**CAUTION: KEEP PEOPLE AND OBJECTS CLEAR OF THE VEHICLE WHILE OPERATING THE HYDRAULIC LEVELING SYSTEM.**

The ignition key must be on and the park brake must be set to use manual hydraulic leveling. If the ignition and/or the park brake are not on, a message will appear on the screen when the "MANUAL HYD LEVEL" button is pushed. Push the "HOME" button and correct the problem before pushing the "MANUAL HYD LEVEL" button again.

**NOTE: Manual leveling and automatic store can only be started when the "HOME" page is being displayed.**

Level the vehicle according to level sensing lights. A lit level sensing light indicates that side, end or corner of the vehicle is low. When all level sensing lights are out the vehicle is level.

The "RAISE" buttons are used to extend the jacks and raise the vehicle. The "LOWER" buttons are used to retract the jacks. Each set of buttons operate a pair of jacks, front, rear, left or right side. The RAISE and LOWER buttons are momentary buttons. The jacks will extend or retract while the buttons are being pushed.

The Jack Down Warning Lights will come on as there respective jack extends approximately 1 inch.

1. Turn the ignition key on and set the park brake.
2. Push the "MANUAL HYD LEVEL" button on the "HOME" page.

3. At this time, the operator may want to check the jacks and place a pad under each jack at this time, if necessary.

4. Push and hold the "DUMP" button until all of the air is exhausted from the vehicle suspension.

5. Push and hold the "RAISE" buttons as necessary to raise the vehicle according to lit LEVEL SENSING lights. If a side LEVEL SENSING light is on, extend that pair of jacks to turn the side light out first before leveling the vehicle from front to rear.

6. Any jack(s) not used for leveling should be extended to the ground to stabilize the vehicle. Use the front and/or rear "RAISE" button to accomplish this. Jacks extended to stabilize the vehicle should lift the vehicle at least 3/4 of an inch.

**IMPORTANT: DO NOT continue to push a "RAISE" button for more than 10 seconds after that pair of jacks are fully extended.**

7. When the leveling and stabilizing procedure is complete, push the "HOME" button and turn the ignition off or proceed with other functions.

**IMPORTANT: Although the jacks can be retracted using the "LOWER" buttons the "AUTO STORE" button on the "HOME" page should be used to retract the jacks. Always use the "AUTO STORE" button when preparing to travel.**

# OPERATING PROCEDURES

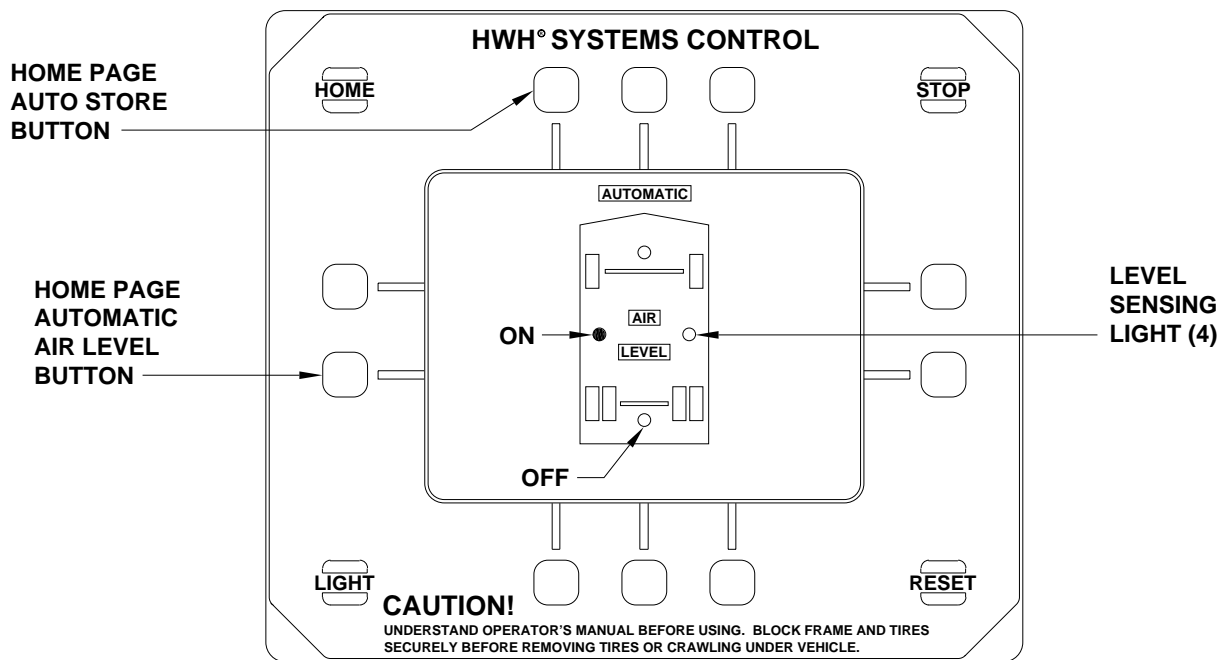

## AUTOMATIC AIR LEVELING

**WARNING:** KEEP PEOPLE AND OBJECTS CLEAR OF THE VEHICLE WHILE OPERATING THE HYDRAULIC LEVELING SYSTEM.

**NOTE:** It is recommended the tag axle is in the travel position before using the air leveling system. If the tag lift function is on, push the "TAG LIFT" button to turn the tag lift feature off.

The ignition key must be on and the park brake must be set to use automatic air leveling. If the ignition and/or the park brake are not on, a message will appear on the screen when the "AUTOMATIC AIR LEVEL" button is pushed. Push the "HOME" button and correct the problem before pushing the "AUTOMATIC AIR LEVEL" button again.

**NOTE:** Automatic leveling and automatic store can only be started when the "HOME" page is being displayed.

The system will level the vehicle according to level sensing lights. A lit level sensing light indicates that side, end or corner of the vehicle is low. When all level sensing lights are out the vehicle is level.

**NOTE:** Only one or two LEVEL SENSING lights may be on at one time.

1. Turn the ignition key on and set the park brake. Leaving the engine running during leveling is recommended. This will provide a better air supply for leveling. The vehicle will level with the engine shut off, however more time will be required for leveling.

2. Push the AUTOMATIC AIR LEVEL button on the HOME page. The AUTOMATIC AIR LEVEL page will appear. The air leveling process will begin. The system will attempt to level the vehicle by exhausting air from the air bags. If a

level position is not achieved by lowering the vehicle, the low side and/or end of the vehicle will be raised by adding air to the air bags. When all four yellow LEVEL SENSING lights are out the leveling is complete. The system will be in the SLEEP MODE. The screen will display a message for 45 seconds, then return to the HOME PAGE. The screen will turn off after 10 minutes if the ignition is turned off.

3. SLEEP MODE: If automatic air leveling is successful the system will be in the SLEEP MODE when all 4 level sensing lights go out. The system will remain in the SLEEP MODE until the "STOP" button is pushed or the park brake is released with the ignition on.

**NOTE:** The system will remain in the SLEEP MODE even with the screen off.

In the SLEEP MODE, the system will check the level sensing unit every 30 minutes. If an input is on continuously for one minute, the system will relevel the vehicle.

When releveling the vehicle the screen will turn on and display the AUTOMATIC LEVELING SCREEN. When all level lights are turned off, the system will return to the SLEEP MODE in the same manner as before.

**EXCESS SLOPE:** The system will attempt to level the vehicle for 15 to 20 minutes. If the automatic leveling attempt is not successful, the system will go into EXCESS SLOPE. The screen will display an EXCESS SLOPE message. This message will remain on the screen until the "HOME" button is pushed or if the ignition is off, the screen will turn off 10 minutes later.

# OPERATING PROCEDURES

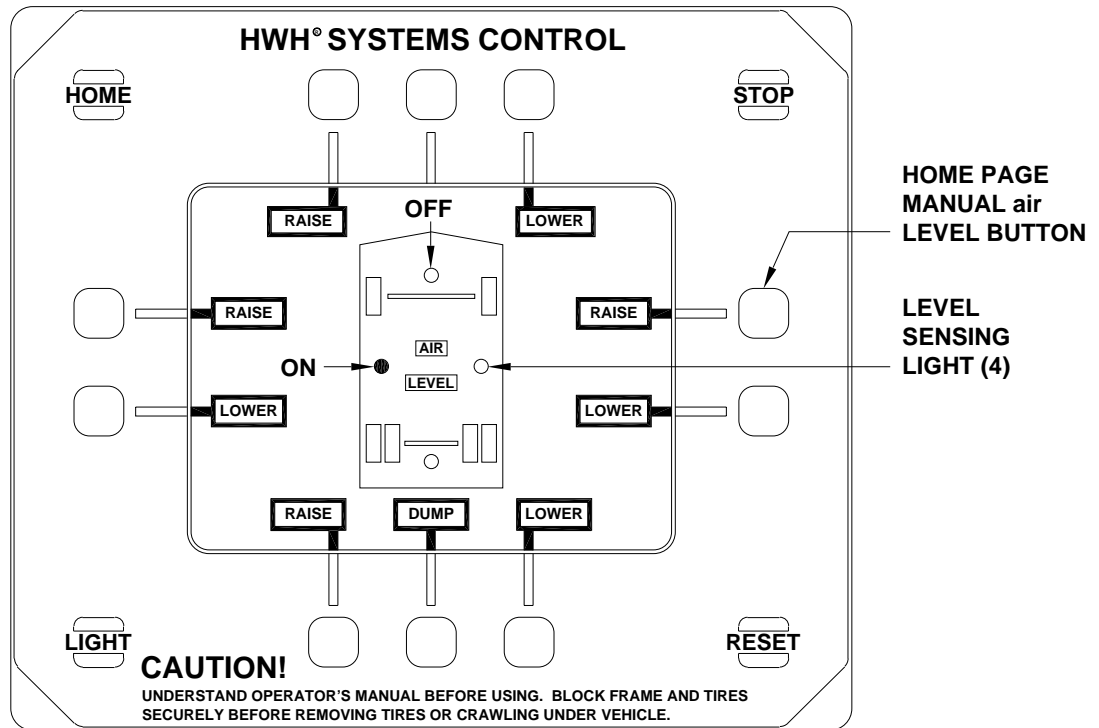

## MANUAL AIR LEVELING

**WARNING: KEEP PEOPLE AND OBJECTS CLEAR OF THE VEHICLE WHILE OPERATING THE AIR LEVELING SYSTEM.**

**NOTE: It is recommended the tag axle is in the travel position before using the air leveling system. If the tag lift function is on, push the "TAG LIFT" button to turn the tag lift feature off.**

1. Place the ignition key in the "ON" position. Transmission must be in the proper position for parking and the park brake must be set to use MANUAL AIR LEVELING. Running the vehicle during leveling is recommended. This will provide a better air supply for leveling. The vehicle will level with the engine shut off, however more time will be required for leveling.

2. Push the "MANUAL AIR LEVEL" button located on "HOME PAGE 1". If the ignition and/or the park brake are not in the recommended positions, when the "MANUAL AIR LEVEL" button is pushed, a message will appear on the screen. Push the "HOME" button and correct the problem before pushing the "MANUAL AIR LEVEL" button again.

The LEVEL SENSING LIGHTS indicate which side, end or corner of the vehicle is low. No more than two level lights should be on at any one time. The vehicle is level when all LEVEL SENSING LIGHTS are off.

3. To level, use the "LOWER" buttons to exhaust air from the corresponding air bags. Use the "RAISE" buttons to add air to the corresponding air bags. The "RAISE" and "LOWER" buttons are momentary buttons. The bags will inflate or deflate only when the buttons are being pushed.

**NOTE: Any side to side leveling should be done, if needed, before leveling the vehicle front to rear.**

Try leveling the vehicle by lowering the high side or end (opposite of the lit level lights). If a level position is not achieved use the RAISE button to raise the low side or end.

**NOTE: Pushing and holding the "DUMP" button will exhaust air from all bags of the vehicle suspension.**

4. When the leveling procedure is complete, the engine can be turned off.

---

# OPERATING PROCEDURES

---

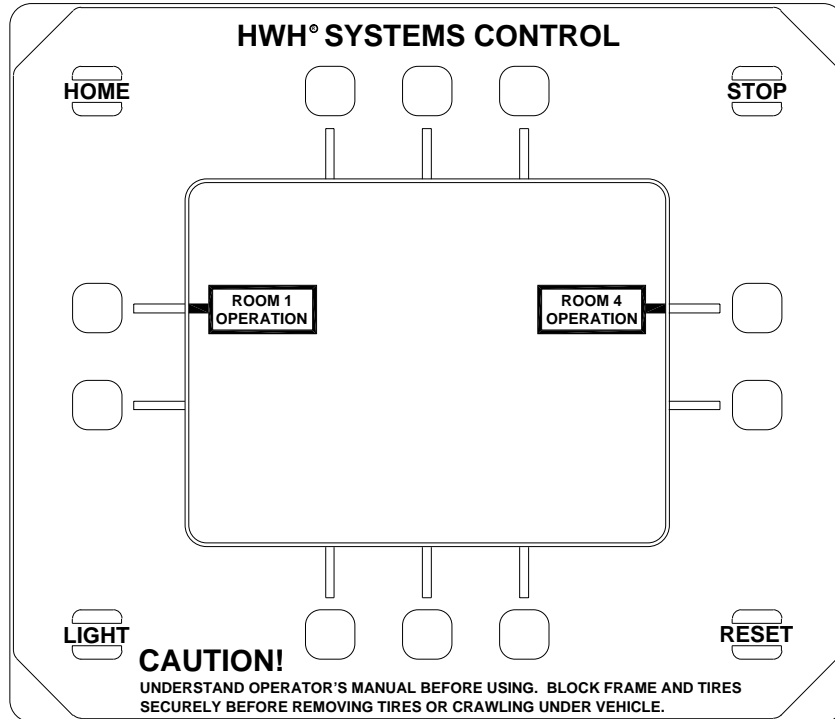

## ROOM SELECTION

1. Push the "ROOM" button on the "HOME" page to access the ROOM SELECTION page.
2. Push the corresponding button to select a room or generator slide that is to be operated. A ROOM OPERATION page will be displayed.

The park brake must be set to access the ROOM SELECTION page. If the park brake is not set, a message will appear when the ROOM button on the "HOME" page is pushed. The operator is directed to push the "HOME" button and correct the problem.

If an attempt to level the vehicle in an automatic leveling mode fails putting the system in an EXCESS SLOPE situation, rooms cannot be extended. Individual ROOM OPERATION pages can be accessed from the ROOM SELECTION page, but when the EXTEND button is pushed, a message will appear directing the operator to push the HOME button and resolve the EXCESS SLOPE situation.

Rooms can be retracted when the leveling system is in an EXCESS SLOPE situation.

**NOTE:** See "EXCESS SLOPE" in the AUTOMATIC HYD or AIR procedures for detailed explanation of "EXCESS SLOPE".

[RETURN to room selection panel](#)

# OPERATING PROCEDURES

## LCD ROOM 1

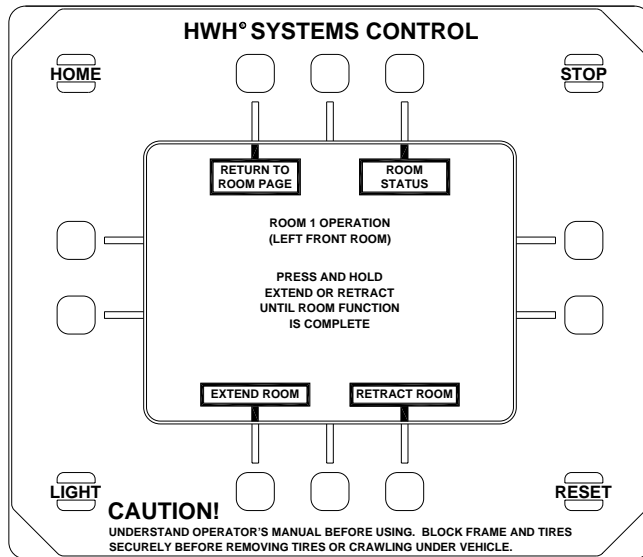

### ROOM 1 EXTEND/RETRACT/STATUS

**WARNING:** OPERATING A ROOM WITH ANY ROOM LOCKING, CLAMPING OR MANUAL RETRACTING DEVICES ATTACHED OR ENGAGED CAN CAUSE PERSONAL INJURY AND VEHICLE DAMAGE. IT IS THE OPERATOR'S RESPONSIBILITY TO ENSURE THAT ALL ROOM LOCKING, CLAMPING OR MANUAL RETRACTING DEVICES ARE DETACHED OR DISENGAGED BEFORE OPERATING THE ROOM.

It is recommended to complete the Leveling Procedure before operating room extensions.

1. Unlock all room-locking devices.

**NOTE:** If a MANUAL RETRACT device is attached to the room remove it before extending the room.

**WARNING:** KEEP PEOPLE AND OBSTRUCTIONS CLEAR OF ROOM WHEN OPERATING.

**NOTE:** Make sure there is adequate clearance to fully extend the room.

2. To extend the room, press and hold the EXTEND ROOM button until the room is fully extended. The EXTEND ROOM LIGHT will flash while the button is being pushed.

**NOTE:** Hold the switch to "EXTEND" three or four seconds after the room is fully extended. This assures proper pressurization of the cylinders. **During normal operation of the room, do not reverse direction of the room until the room is fully extended. If necessary, the direction of the room may be reversed, but watch for binding of the room. If the direction of the room has been reversed, DO NOT re-extend the room until the room has been fully extended.**

**IMPORTANT:** Do not hold the ROOM CONTROL SWITCH in the "EXTEND" position for more than ten seconds after the room is fully extended or stops moving. **If either side of the room stops moving, release the room control switch immediately. DO NOT force the room. DO NOT reverse direction of the room, contact HWH Customer Service for assistance 1-800-321-3494.**

**NOTE:** Releasing the ROOM CONTROL SWITCH will halt the operation of the room.

### ROOM RETRACT PROCEDURE

**WARNING:** KEEP PEOPLE AND OBSTRUCTIONS CLEAR OF ROOM WHEN OPERATING.

It is recommended to retract room extensions before retracting the hydraulic leveling system.

1. To retract the room press and hold the RETRACT ROOM button until the room is fully retracted. The RETRACT ROOM light will flash while the button is being pushed.

**NOTE:** Hold the switch to "RETRACT" three or four seconds after the room is fully retracted. This assures proper pressurization of the cylinders. **During normal operation of the room, do not reverse direction of the room until the room is fully retracted. If necessary, the direction of the room may be reversed, but watch for binding of the room. If the direction of the room has been reversed, DO NOT retract the room until the room has been fully extended.**

**IMPORTANT:** Do not hold the ROOM CONTROL SWITCH in the "RETRACT" position for more than ten seconds after the room is fully retracted or stops moving. **If either side of the room stops moving, release the room control switch immediately. DO NOT force the room. DO NOT reverse direction of the room, contact HWH Customer Service for assistance 1-800-321-3494.**

**NOTE:** Releasing the ROOM CONTROL SWITCH will halt the operation of the room.

2. Engage all room-locking devices.

3. If the room will not retract see the MANUAL ROOM RETRACT PROCEDURE.

**IMPORTANT:** Room-locking devices should be locked while traveling.

**RETURN TO ROOM PAGE BUTTON:** This button will return the screen to the ROOM SELECTION page.

**ROOM STATUS BUTTON:** This button will display a page showing the status of assorted room or lock limit switches being used if applicable.

# OPERATING PROCEDURES

## LCD ROOM 4

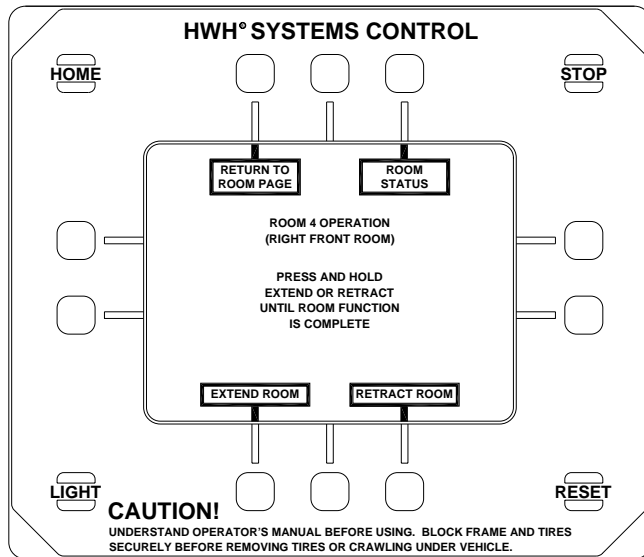

### ROOM 4 EXTEND/RETRACT/STATUS

**WARNING:** OPERATING A ROOM WITH ANY ROOM LOCKING, CLAMPING OR MANUAL RETRACTING DEVICES ATTACHED OR ENGAGED CAN CAUSE PERSONAL INJURY AND VEHICLE DAMAGE. IT IS THE OPERATOR'S RESPONSIBILITY TO ENSURE THAT ALL ROOM LOCKING, CLAMPING OR MANUAL RETRACTING DEVICES ARE DETACHED OR DISENGAGED BEFORE OPERATING THE ROOM.

It is recommended to complete the Leveling Procedure before operating room extensions.

1. Unlock all room-locking devices.

**NOTE:** If a MANUAL RETRACT device is attached to the room remove it before extending the room.

**WARNING:** KEEP PEOPLE AND OBSTRUCTIONS CLEAR OF ROOM WHEN OPERATING.

**NOTE:** Make sure there is adequate clearance to fully extend the room.

2. To extend the room, press and hold the EXTEND ROOM button until the room is fully extended. The EXTEND ROOM LIGHT will flash while the button is being pushed.

**NOTE:** Hold the switch to "EXTEND" three or four seconds after the room is fully extended. This assures proper pressurization of the cylinders. **During normal operation of the room, do not reverse direction of the room until the room is fully extended. If necessary, the direction of the room may be reversed, but watch for binding of the room. If the direction of the room has been reversed, DO NOT re-extend the room until the room has been fully extended.**

**IMPORTANT:** Do not hold the ROOM CONTROL SWITCH in the "EXTEND" position for more than ten seconds after the room is fully extended or stops moving. **If either side of the room stops moving, release the room control switch immediately. DO NOT force the room. DO NOT reverse direction of the room, contact HWH Customer Service for assistance 1-800-321-3494.**

**NOTE:** Releasing the ROOM CONTROL SWITCH will halt the operation of the room.

### ROOM RETRACT PROCEDURE

**WARNING:** KEEP PEOPLE AND OBSTRUCTIONS CLEAR OF ROOM WHEN OPERATING.

It is recommended to retract room extensions before retracting the hydraulic leveling system.

1. To retract the room press and hold the RETRACT ROOM button until the room is fully retracted. The RETRACT ROOM light will flash while the button is being pushed.

**NOTE:** Hold the switch to "RETRACT" three or four seconds after the room is fully retracted. This assures proper pressurization of the cylinders. **During normal operation of the room, do not reverse direction of the room until the room is fully retracted. If necessary, the direction of the room may be reversed, but watch for binding of the room. If the direction of the room has been reversed, DO NOT retract the room until the room has been fully extended.**

**IMPORTANT:** Do not hold the ROOM CONTROL SWITCH in the "RETRACT" position for more than ten seconds after the room is fully retracted or stops moving. **If either side of the room stops moving, release the room control switch immediately. DO NOT force the room. DO NOT reverse direction of the room, contact HWH Customer Service for assistance 1-800-321-3494.**

**NOTE:** Releasing the ROOM CONTROL SWITCH will halt the operation of the room.

2. Engage all room-locking devices.

3. If the room will not retract see the MANUAL ROOM RETRACT PROCEDURE.

**IMPORTANT:** Room-locking devices should be locked while traveling.

**RETURN TO ROOM PAGE BUTTON:** This button will return the screen to the ROOM SELECTION page.

**ROOM STATUS BUTTON:** This button will display a page showing the status of assorted room or lock limit switches being used if applicable.

# HWH® SYSTEMS CONTROL

HOME

STOP

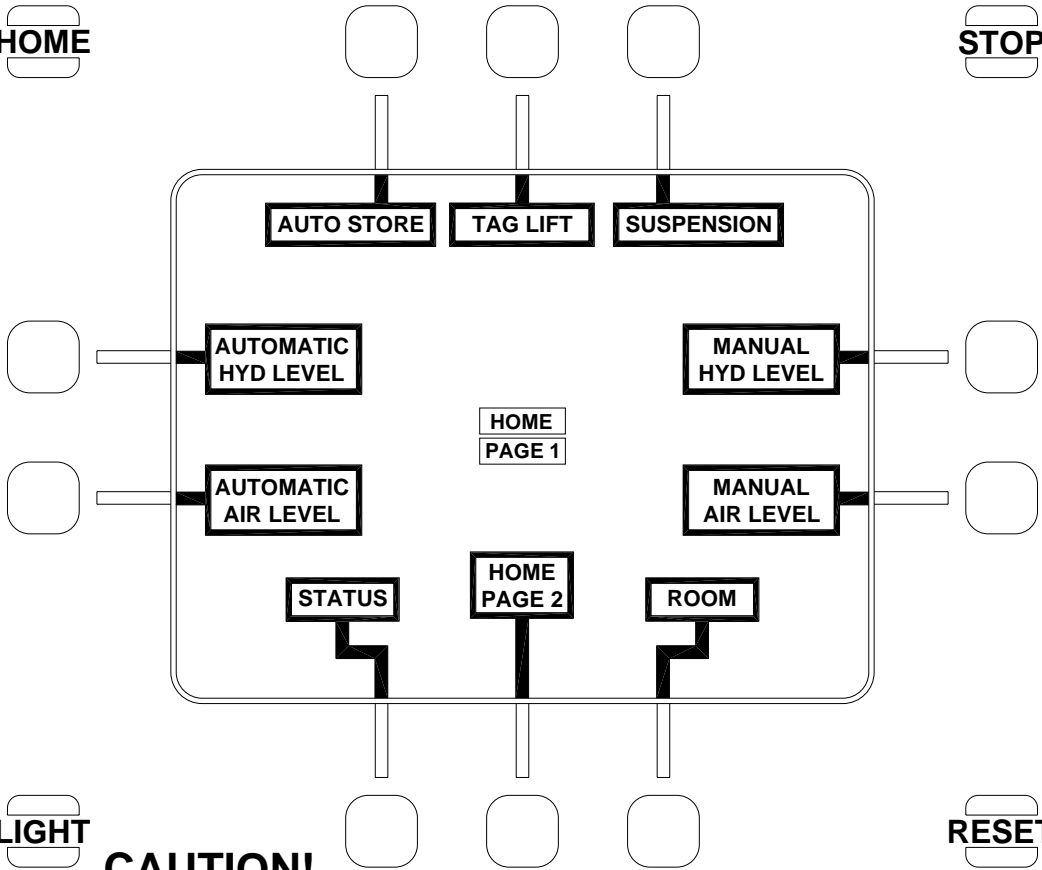

**CAUTION!**

UNDERSTAND OPERATOR'S MANUAL BEFORE USING. BLOCK FRAME AND TIRES SECURELY BEFORE REMOVING TIRES OR CRAWLING UNDER VEHICLE.

**HOME PAGE 1**

[CLICK to view HOME PAGE 1 button and light descriptions.](#)

# HWH® SYSTEMS CONTROL

HOME

STOP

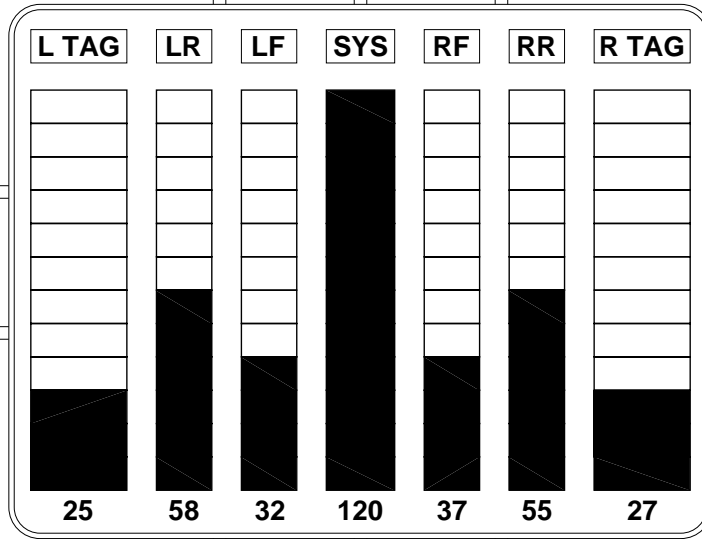

LIGHT

RESET

**CAUTION!**

UNDERSTAND OPERATOR'S MANUAL BEFORE USING. BLOCK FRAME AND TIRES SECURELY BEFORE REMOVING TIRES OR CRAWLING UNDER VEHICLE.

## BAG PRESSURE STATUS PAGE

**BAG PRESSURE STATUS PAGE:** Each column represents a particular bag or the system pressure. Each block represents a 10 p.s.i. increment. The numbers represent an approximate p.s.i. reading.

**"AUTO STORE" BUTTON:** This button will retract the jacks when manual or automatic hydraulic leveling has been used. It also puts the system in the Travel Mode.

If Manual or Automatic Air Leveling was used, this button will put the system in the Travel Mode.

No matter what type of leveling was done, when the "AUTO STORE" button is pushed the first thing that happens is air is pumped into all the suspension air bags for 10 seconds before the jacks are retracted and/or the system returns to the Travel Mode.

## TAG LIFT

[CLICK HERE](#)

### **IMPORTANT: REFER TO THE VEHICLE MANUFACTURER FOR PROPER USE OF THE TAG LIFT FEATURE.**

The ignition must be on, system air pressure must be at least approximately 50 psi and the vehicle cannot be traveling faster than approximately 10 mph for the tag lift feature to function.

To use the tag lift, push the "TAG LIFT" button. The "TAG LIFT" letters will turn white with a black background. The tag will remain in the lift position until the "TAG LIFT" button is pushed again or the vehicle exceeds approximately 10 mph. The "TAG LIFT" letters will turn black with a white background when the feature is off.

It is recommended to have the tag in the travel position before using the leveling system.

**"TAG LIFT" BUTTON:** This button will lift the tag axle. See the "TAG LIFT" section in "OPERATING PROCEDURES".

**"TAG LIFT" LIGHT:** When the letters are black and the background is white, the tag lift is off. The tag axle should be in the Travel Position. When the letters are white and the background is black, the tag lift feature is on. The tag axle should be in the Lift Position.

# HWH® SYSTEMS CONTROL

HOME

STOP

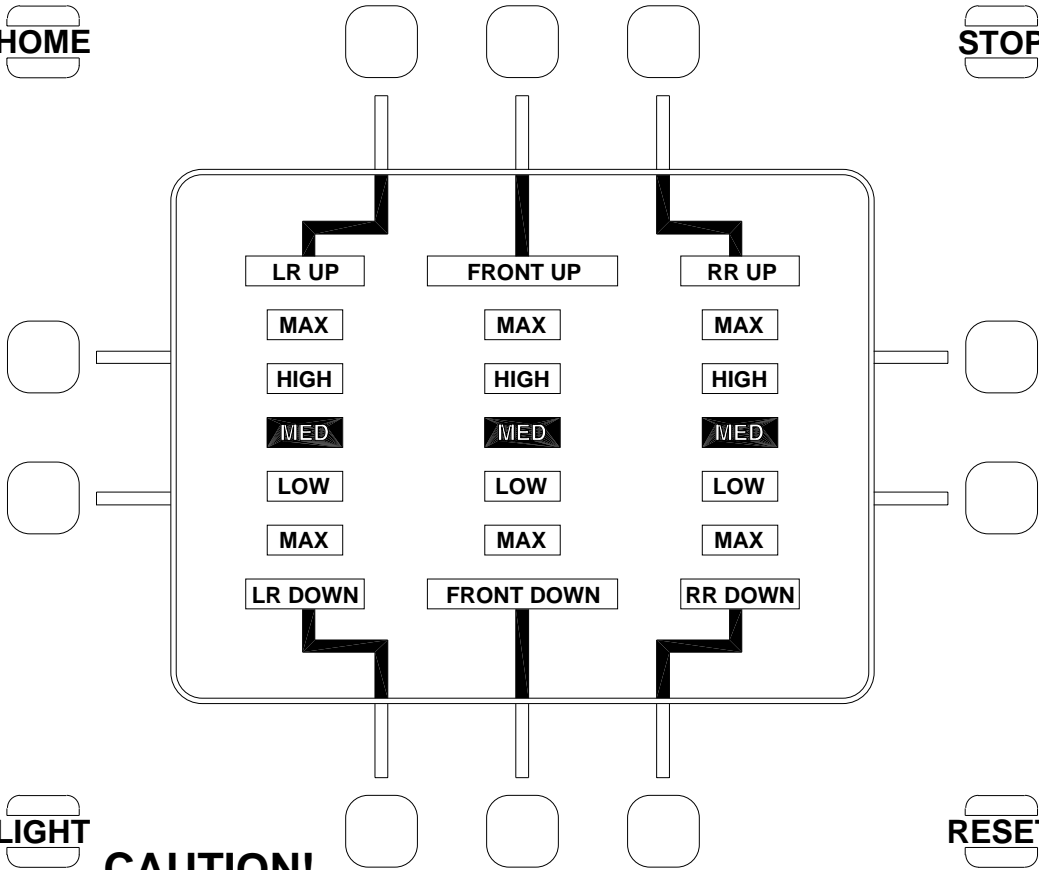

**CAUTION!**

UNDERSTAND OPERATOR'S MANUAL BEFORE USING. BLOCK FRAME AND TIRES SECURELY BEFORE REMOVING TIRES OR CRAWLING UNDER VEHICLE.

## SUSPENSION CONTROL

[CLICK HERE](#) for button and light information.

# HWH® SYSTEMS CONTROL

HOME

STOP

STATUS PAGE 4

AIR SUSPENSION PRESSURE  
SWITCH INFORMATION

SYSTEM AIR PRESS. SWITCH	OFF
LF AIR PRESSURE SWITCH	OFF
RF AIR PRESSURE SWITCH	OFF
LR AIR PRESSURE SWITCH	OFF
RR AIR PRESSURE SWITCH	ON
L TAG PRESSURE SWITCH	OFF
R TAG PRESSURE SWITCH	OFF

PAGE DOWN

LIGHT

RESET

**CAUTION!**

UNDERSTAND OPERATOR'S MANUAL BEFORE USING. BLOCK FRAME AND TIRES  
SECURELY BEFORE REMOVING TIRES OR CRAWLING UNDER VEHICLE.

**STATUS PAGE 4**

[CLICK HERE for status page 4 item descriptions](#)

# HWH® SYSTEMS CONTROL

HOME

STOP

## STATUS PAGE 3

SUSPENSION MODE	RIDE HEIGHT
PARK BRAKE	ON
EXCESS SLOPE	OFF
SLEEP MODE	OFF
AIR FLAG	OFF
HYD FLAG	OFF
SPEED SWITCH	UNDER
LEFT LEVEL SENSOR	ON
FRONT LEVEL SENSOR	OFF
RIGHT LEVEL SENSOR	OFF
REAR LEVEL SENSOR	OFF

PAGE DOWN

LIGHT

RESET

**CAUTION!**

UNDERSTAND OPERATOR'S MANUAL BEFORE USING. BLOCK FRAME AND TIRES SECURELY BEFORE REMOVING TIRES OR CRAWLING UNDER VEHICLE.

## STATUS PAGE 3

[CLICK HERE](#) for status page 3 item descriptions

# HWH® SYSTEMS CONTROL

HOME

STOP

## STATUS PAGE 2

LF JACK WARNING SWITCH	OFF
RF JACK WARNING SWITCH	OFF
LR JACK WARNING SWITCH	OFF
RR JACK WARNING SWITCH	OFF

LF HYD PRESSURE SWITCH	OFF
RF HYD PRESSURE SWITCH	OFF
LR HYD PRESSURE SWITCH	OFF
RR HYD PRESSURE SWITCH	OFF

PAGE DOWN

LIGHT

RESET

**CAUTION!**

UNDERSTAND OPERATOR'S MANUAL BEFORE USING. BLOCK FRAME AND TIRES SECURELY BEFORE REMOVING TIRES OR CRAWLING UNDER VEHICLE.

## STATUS PAGE 2

[CLICK HERE](#) for status page 2 item descriptions

# HWH® SYSTEMS CONTROL

HOME

STOP

## STATUS PAGE 1

STEERING POSITION	ECONOMY
FT SENSOR STATUS	LOW
LR SENSOR STATUS	LOW
RR SENSOR STATUS	LOW
LATERAL FORCE	OFF
LF AIR SOLENOID	OFF
RF AIR SOLENOID	RAISE
LR AIR SOLENOID	RAISE
LR HV SOLENOID	OFF
RR AIR SOLENOID	RAISE
RR HV SOLENOID	OFF

PAGE DOWN

LIGHT

RESET

**CAUTION!**

UNDERSTAND OPERATOR'S MANUAL BEFORE USING. BLOCK FRAME AND TIRES SECURELY BEFORE REMOVING TIRES OR CRAWLING UNDER VEHICLE.

## STATUS PAGE 1

[CLICK HERE](#) for status page 1 item descriptions

# HWH® SYSTEMS CONTROL

HOME

STOP



**BAG PRESS  
STATUS**

HOME  
PAGE 2

**HOME PAGE 3**



LIGHT

**CAUTION!**

UNDERSTAND OPERATOR'S MANUAL BEFORE USING. BLOCK FRAME AND TIRES  
SECURELY BEFORE REMOVING TIRES OR CRAWLING UNDER VEHICLE.

RESET

## HOME PAGE 2

## SCREEN BUTTONS

**"BAG PRESSURE STATUS" BUTTON:** This button will take you to the following screen.

**"STOP" BUTTON:** Pushing the "STOP" button will turn the system off halting any active function including ACTIVE AIR SUSPENSION. If the ignition is on, the Master Warning Light will come on. **IT IS NOT RECOMMENDED TO PUSH THE "STOP" BUTTON WHEN TRAVELING.**

[CLICK HERE](#)

**"RESET" BUTTON:** This button will reset the SYSTEM CONTROL PANEL if the panel ceases to function due to a malfunction. The "RESET" button will also reactivate the CONTROL PANEL if the "STOP" button is pushed at ANY time. The ignition key must be on for the "RESET" button to work.

[CLICK HERE](#)

# HWH® SYSTEMS CONTROL

HOME

STOP



ROOM 1  
OPERATION

ROOM 4  
OPERATION



LIGHT

RESET

**CAUTION!**

UNDERSTAND OPERATOR'S MANUAL BEFORE USING. BLOCK FRAME AND TIRES  
SECURELY BEFORE REMOVING TIRES OR CRAWLING UNDER VEHICLE.

## ROOM SELECTION

[CLICK HERE](#) for button and light information

# HWH® SYSTEMS CONTROL

HOME

STOP

RETURN TO  
ROOM PAGE

ROOM  
STATUS

UF LOCK      N/A  
UR LOCK      N/A

LF LOCK      N/A  
LR LOCK      N/A

UF UNLOCK    N/A  
UR UNLOCK    N/A

LF UNLOCK    N/A  
LR UNLOCK    N/A

FNT RM IN    ON  
REAR RM IN   N/A

ROOM OUT    OFF  
VAC. SENSE   OFF

EXTEND ROOM

RETRACT ROOM

LIGHT

RESET

**CAUTION!**

UNDERSTAND OPERATOR'S MANUAL BEFORE USING. BLOCK FRAME AND TIRES SECURELY BEFORE REMOVING TIRES OR CRAWLING UNDER VEHICLE.

## ROOM STATUS

**"LIGHT" BUTTON:** Pushing the "LIGHT" button will turn the back light off. The panel will appear dark but the system will remain on. Push the "LIGHT" button to turn the light back on.

[CLICK HERE](#)